

Code No: 134AM

JAWAHARLAL NEHRU TECHNOLOGICAL UNIVERSITY HYDERABAD

B.Tech II Year II Semester Examinations, May - 2019

CONTROL SYSTEMS

(Common to EEE, ECE, EIE, ETM)

Time: 3 Hours

Max. Marks: 75

Note: This question paper contains two parts A and B.

Part A is compulsory which carries 25 marks. Answer all questions in Part A.

Part B consists of 5 Units. Answer any one full question from each unit.

Each question carries 10 marks and may have a, b as sub questions.

PART – A

(25 Marks)

- 1.a) Classify the following as open or closed loop system with valid reasons (i) An electrical On-Off switch, (ii) Room air-conditioner. [2]
- b) Why do you need a feedback controller? Justify your answer with an example. [3]
- c) What are the effects of integral control action? [2]
- d) Find the peak overshoot for unit step response of the system described by closed loop transfer function, $G(s) = \frac{64}{s^2 + 16s + 64}$. [3]
- e) Outline the Bode plot for a Proportional Integral controller. [2]
- f) Compare between absolute stability, conditional stability and relative stability. [3]
- g) Draw the polar plot for $G(s)H(s) = \frac{1+2s}{1+3s}$. [2]
- h) What is a Phase Lag compensator and why is it used? [3]
- i) What are the advantages of State variable model of dynamic system? [2]
- j) How do you determine the system eigen values and what is its role in the system response? [3]

PART – B

(50 Marks)

- 2. Determine the transfer function for the block diagram shown in Figure 1. [10]

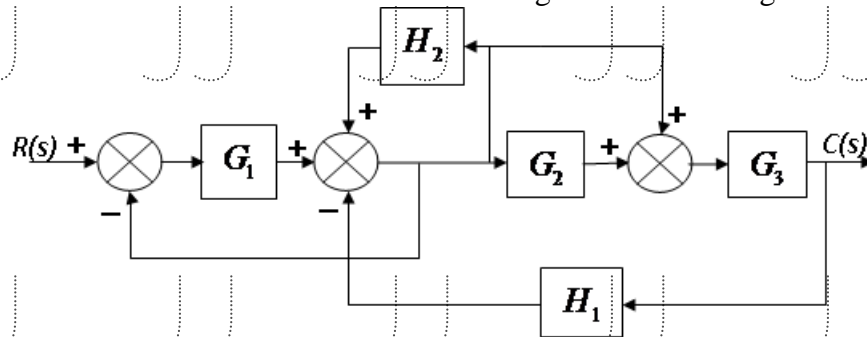

Figure: 1

OR

- 3.a) Distinguish between Open loop control system and closed loop control system.
 b) A two phase AC servo motor has the following parameters:
 Starting torque = 0.166 N-m
 Inertia = 1×10^{-5} kg-m²
 Supply voltage = 115 V
 No load angular velocity = 304 rad/sec
 Assuming torque – speed curve to be linear and zero viscous friction, derive the transfer function. [4+6]

4. The open loop transfer function of an unity feedback control system is given as

$$G(s) = \frac{K}{s(1+sT)}$$
 Determine the factor by which the gain 'K' should be multiplied so that the overshoot of the unity step response be reduced from 80% to 25%? [10]

OR

- 5.a) Determine the damping ratio and natural frequency of the system if the derivative feedback is absent ($K_0=0$) in the closed loop system shown in Figure 2. What is the steady state error resulting from unit ramp input?
 b) Determine the derivative feedback constant 'K₀' which will increase the damping ratio of the system to 0.5. What is the steady state error resulting from unit ramp input with this setting of the derivative feedback constant? [5+5]

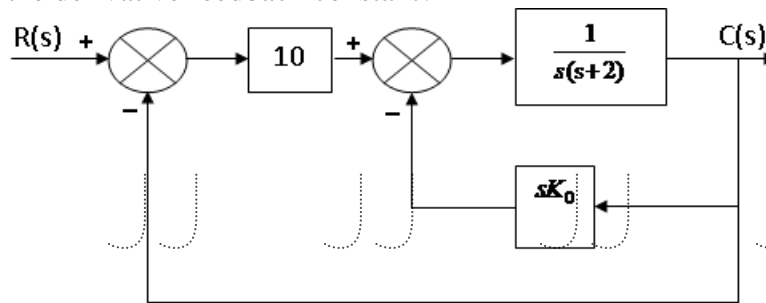

Figure: 2

6. Determine the values of K and β , so that the system whose open loop transfer function is

$$G(s) = \frac{K(s+1)}{s^3 + \beta s^2 + 5s + 1}$$
 oscillates at a frequency of oscillations of 2 rad/sec. Assume unity feedback. [10]

OR

7. Sketch the root locus of the unity feedback system having $G(s) = \frac{K}{s^2 + 2s + 2}$ for positive values of K. Sketch the new root locus when a simple pole at $s = -5$ is added to the system loop transfer function. Hence indicate the effect of adding this pole on the root locus of the system. [10]

8. Investigate closed loop stability of a system having $G(s)H(s) = \frac{K(s+4)}{s(s-2)}$ using Nyquist criterion. Determine the limiting value of 'K' for stability. [10]

OR

9. Design a lead compensator for the system with an open-loop transfer function $G(s) = \frac{K}{s^2(1+0.1s)}$ for the specifications of acceleration error constant, $K_a = 10$ and phase margin, $\phi_{pm} = 30^\circ$. [10]

10. For the system given below, obtain:

- a) Zero input response
b) Zero state response
c) Total response.

$$A = \begin{bmatrix} 1 & 4 \\ -2 & -5 \end{bmatrix}, B = \begin{bmatrix} 0 \\ 1 \end{bmatrix}, u = 1 \text{ and } \begin{matrix} x_1(0) = 1 \\ x_2(0) = 0 \end{matrix}$$

OR

- 11.a) Distinguish between Transfer function model and State Space model.
b) Diagonalize the system matrix given below. [4+6]

$$A = \begin{bmatrix} 0 & 1 & 0 \\ 0 & 0 & 1 \\ -2 & -5 & -4 \end{bmatrix}$$

---ooOoo---

Code No: 134AM

JAWAHARLAL NEHRU TECHNOLOGICAL UNIVERSITY HYDERABAD

B.Tech II Year II Semester Examinations, December - 2019

CONTROL SYSTEMS

(Common to EEE, ECE, EIE, ETM)

Time: 3 Hours

Max. Marks: 75

Note: This question paper contains two parts A and B.

Part A is compulsory which carries 25 marks. Answer all questions in Part A.

Part B consists of 5 Units. Answer any one full question from each unit.

Each question carries 10 marks and may have a, b, c as sub questions.

PART- A

(25 Marks)

- 1.a) What are the different types of control system? [2]
- b) What is the difference between AC servo motor and D.C servo motor? [3]
- c) What is the difference between type and order of a system? [2]
- d) What is the need of PID controller? [3]
- e) What is the necessary condition that the characteristic equation of a feedback system satisfies the BIBO stability? [2]
- f) What are the advantages of frequency domain analysis? [3]
- g) State the Nyquist criterion. [2]
- h) What is the effect on polar plot if a pole is added to the transfer function? [3]
- i) What is state? [2]
- j) What are the advantages of state variable techniques? [3]

PART-B

(50 Marks)

- 2.a) Contrast differences between open loop and closed loop control systems.
- b) Develop the differential equations governing the mechanical system as shown in below figure. Also find the transfer function $\frac{x_1(S)}{F(S)}$. [5+5]

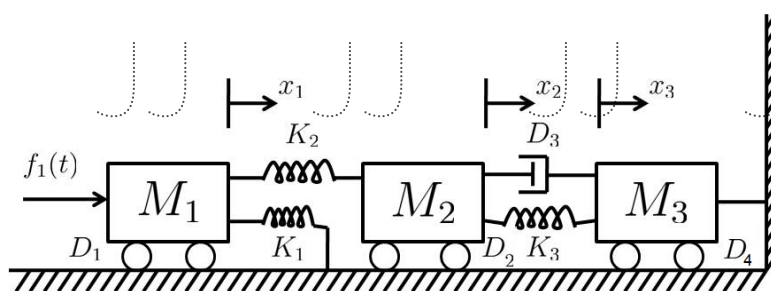

OR

3. Describe the construction and operating principle of synchro transmitter with neat diagrams. [10]
- 4.a) Derive the time domain specifications of second order system with unit step input.
- b) A unity feedback system has a forward path transfer function $G(s) = \frac{8}{s(s+2)}$. Find the value of damping ratio, undamped natural frequency of the system, percentage overshoot, peak time and settling time. [5+5]

OR

5.a) Derive the response of second order system with unit step response.

b) For a negative feedback control system $G(s) = \frac{8}{s(0.4s+1)}$ and $H(s) = \frac{7}{s+2}$. Using generalized error series determine the steady state error of the system when the input applied is $r(t) = 1+2t+5t^2$. [5+5]

6.a) Determine the number of roots of a given polynomial with real parts between zero and -1 , $7s^2 + 4s^4 + 10s^3 + 2s^2 + 3s + 6 = 0$

b) Define and derive the breakaway point on the root locus. [5+5]

OR

7. Sketch the Bode plot and determine the Gain margin and phase margin. For the open transfer function is given, $G(s) = \frac{8}{s(1+0.3s)(1+0.1s)}$ [10]

8.a) Describe the procedure for developing the polar plot.

b) A unity feedback control system has an open loop transfer function given by

$G(s)H(s) = \frac{10}{s(s+3)(s+6)}$. Draw Nyquist diagram and determine stability. [5+5]

OR

9. Consider the open loop transfer function with unit feedback system,

$$G(s) = \frac{k}{s(s+3)(0.4s+1)}$$

Design the lead-lag compensator so that:

a) Velocity error constant K_v is 5 sec^{-1}

b) Phase margin not greater than 30°

c) Gain margin not greater than 10 db. [10]

10.a) Obtain the state space representation of an n^{th} order differential equation.

b) A second order linear system is described by

$$\dot{x}_1 = -2x_1 + 4x_2 + u$$

$$\dot{x}_2 = -x_1 - 2x_2 + u$$

$$\text{and } y = x_1 + x_2$$

Find the transfer function and also calculate the zero input response of $x_{1(0)} = 1$ and $x_{2(0)} = -1$. [5+5]

OR

11. The state variable formulation of a system is given by

$$\begin{bmatrix} \dot{x} \\ \dot{x} \end{bmatrix} = \begin{bmatrix} -3 & 2 \\ -1 & 0 \end{bmatrix} [x] + \begin{bmatrix} 0 \\ 1 \end{bmatrix} u \text{ and } y = \begin{bmatrix} 1 & 0 \end{bmatrix} [x]$$

Find the following:

a) Transfer function of the system

b) State transition matrix and

c) State equation for a unit step input under zero initial condition. [10]

---ooOoo---

Note: This question paper contains two parts A and B.

Part A is compulsory which carries 25 marks. Answer all questions in Part A.

Part B consists of 5 Units. Answer any one full question from each unit.

Each question carries 10 marks and may have a, b, c as sub questions.

PART-A

(25 Marks)

- 1.a) Write the Mason's gain formula. [2]
- b) What are the basic properties of SFG? [3]
- c) What are the standard test signals used in control systems? [2]
- d) Distinguish between type and order of a system. [3]
- e) Define a stable system. [2]
- f) Explain the basics of root locus plot. [3]
- g) What is polar plot? [2]
- h) Define gain and phase margins. [3]
- i) What is state diagram? [2]
- j) Mention any four advantages of state variable representation. [3]

PART-B

(50 Marks)

- 2.a) Compare the AC and DC servomotors.
- b) For the system represented by the block diagram shown in figure 1. Find $\frac{C}{R}$. [4+6]

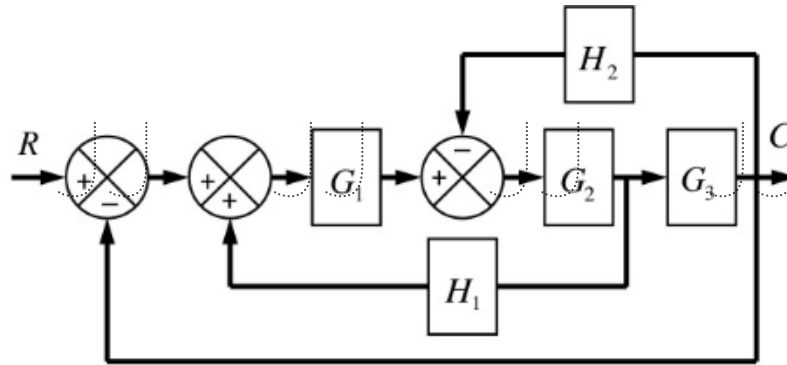

Figure: 1
OR

3.a) What are the characteristics of servomotors?

b) Find the overall gain $\frac{C(s)}{R(s)}$ for the signal flow graph shown in figure 2. [4+6]

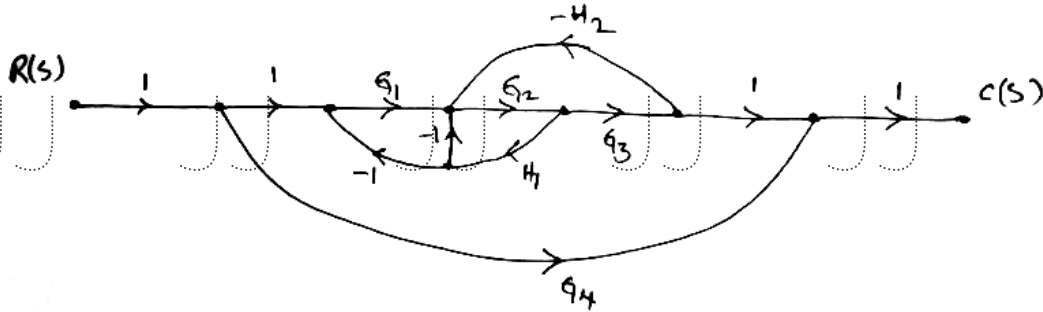

Figure: 2

4. The open-loop transfer function of a unity feedback control system is given by $G(s) = \frac{9}{s(s+3)}$. Find the natural frequency of response, damping ratio, damped frequency and time constant. [10]

OR

5. For unity feedback control system the open loop transfer function, $G(s) = \frac{10(s+2)}{s^2(s+4)}$. Find the e_{ss} when the input is $r(t) = 3 - 2t + 3t^2$. And find $K_p, K_v,$ and K_a . [10]

6.a) Determine the RH stability of given characteristic equation, $s^4 + 8s^3 + 18s^2 + 16s + 5 = 0$.
 b) Sketch the root locus of the system, whose open loop transfer function is,

$$G(s) = \frac{K(s+15)}{s(s+1)(s+5)}$$

OR

7. Given $G(s) = \frac{Ke^{-0.2s}}{s(s+2)(s+8)}$. Find K so that the system is stable with, a) $GM=2db$,
 b) $PM=45^\circ$ [10]

8. The open loop transfer function is given by $G(s)H(s) = \frac{K(1+4s)}{s^2(1+s)(1+2s)}$, Determine the stability of closed loop system. [10]

OR

9. The open-loop transfer function of a system is given by

$$G_p(s) = \frac{K}{s(1+0.1s)(1+0.2s)}$$

Design a lag-lead compensator to meet the $K_v=100sec^{-1}$ and Phase margin $\geq 30^\circ$. [10]

10.a) Define: i) State ii) State variables iii) State space representation.

b) Find the state transition matrix for the following matrix, $A = \begin{bmatrix} 1 & 0 \\ -1 & 1 \end{bmatrix}$.

c) Obtain the state space representation for the following differential equation.
 $\ddot{y} + 5\dot{y} + 7y = 114$

Where 'y' is the output and 'u' is the input.

[10]

OR

11. The state equation of a linear-time invariant system is given as,

$$\dot{X} = \begin{bmatrix} 0 & 5 \\ -1 & -2 \end{bmatrix} X + \begin{bmatrix} 1 \\ 1 \end{bmatrix} r \text{ and } y = [1 \quad 1] X,$$

Find the transfer function and draw the state diagram.

[10]

---ooOoo---

Code No: 134AM

JAWAHARLAL NEHRU TECHNOLOGICAL UNIVERSITY HYDERABAD

B.Tech II Year II Semester Examinations, May - 2019

CONTROL SYSTEMS

(Common to EEE, ECE, EIE, ETM)

Time: 3 Hours

Max. Marks: 75

Note: This question paper contains two parts A and B.

Part A is compulsory which carries 25 marks. Answer all questions in Part A.

Part B consists of 5 Units. Answer any one full question from each unit.

Each question carries 10 marks and may have a, b as sub questions.

PART – A

(25 Marks)

- 1.a) Classify the following as open or closed loop system with valid reasons (i) An electrical On-Off switch, (ii) Room air-conditioner. [2]
- b) Why do you need a feedback controller? Justify your answer with an example. [3]
- c) What are the effects of integral control action? [2]
- d) Find the peak overshoot for unit step response of the system described by closed loop transfer function, $G(s) = \frac{64}{s^2 + 16s + 64}$. [3]
- e) Outline the Bode plot for a Proportional Integral controller. [2]
- f) Compare between absolute stability, conditional stability and relative stability. [3]
- g) Draw the polar plot for $G(s)H(s) = \frac{1+2s}{1+3s}$. [2]
- h) What is a Phase Lag compensator and why is it used? [3]
- i) What are the advantages of State variable model of dynamic system? [2]
- j) How do you determine the system eigen values and what is its role in the system response? [3]

PART – B

(50 Marks)

- 2. Determine the transfer function for the block diagram shown in Figure 1. [10]

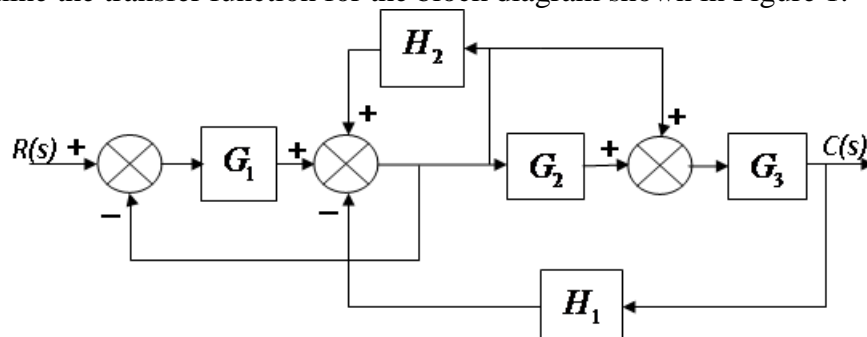

Figure: 1

OR

- 3.a) Distinguish between Open loop control system and closed loop control system.
 b) A two phase AC servo motor has the following parameters:
 Starting torque = 0.166 N-m
 Inertia = 1×10^{-5} kg-m²
 Supply voltage = 115 V
 No load angular velocity = 304 rad/sec
 Assuming torque – speed curve to be linear and zero viscous friction, derive the transfer function. [4+6]

4. The open loop transfer function of an unity feedback control system is given as

$$G(s) = \frac{K}{s(1+sT)}$$
 Determine the factor by which the gain 'K' should be multiplied so that the overshoot of the unity step response be reduced from 80% to 25%? [10]

OR

- 5.a) Determine the damping ratio and natural frequency of the system if the derivative feedback is absent ($K_0=0$) in the closed loop system shown in Figure 2. What is the steady state error resulting from unit ramp input?
 b) Determine the derivative feedback constant ' K_0 ' which will increase the damping ratio of the system to 0.5. What is the steady state error resulting from unit ramp input with this setting of the derivative feedback constant? [5+5]

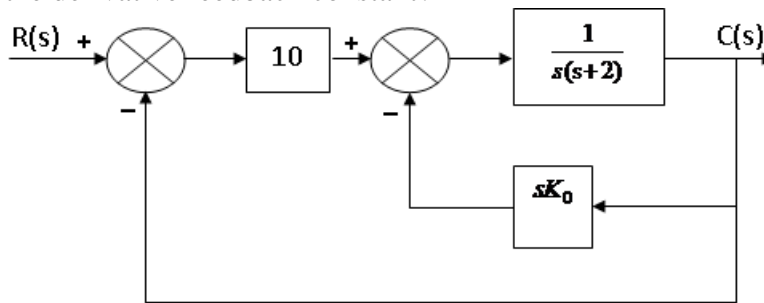

Figure: 2

6. Determine the values of K and β , so that the system whose open loop transfer function is

$$G(s) = \frac{K(s+1)}{s^3 + \beta s^2 + 5s + 1}$$
 oscillates at a frequency of oscillations of 2 rad/sec. Assume unity feedback. [10]

OR

7. Sketch the root locus of the unity feedback system having $G(s) = \frac{K}{s^2 + 2s + 2}$ for positive values of K. Sketch the new root locus when a simple pole at $s = -5$ is added to the system loop transfer function. Hence indicate the effect of adding this pole on the root locus of the system. [10]

8. Investigate closed loop stability of a system having $G(s)H(s) = \frac{K(s+4)}{s(s-2)}$ using Nyquist criterion. Determine the limiting value of 'K' for stability. [10]

OR

9. Design a lead compensator for the system with an open-loop transfer function $G(s) = \frac{K}{s^2(1+0.1s)}$ for the specifications of acceleration error constant, $K_a = 10$ and phase margin, $\phi_{pm} = 30^\circ$. [10]

10. For the system given below, obtain:

- a) Zero input response
 b) Zero state response
 c) Total response.

[10]

$$A = \begin{bmatrix} 1 & 4 \\ -2 & -5 \end{bmatrix}, B = \begin{bmatrix} 0 \\ 1 \end{bmatrix}, u = 1 \text{ and } \begin{matrix} x_1(0) = 1 \\ x_2(0) = 0 \end{matrix}$$

OR

- 11.a) Distinguish between Transfer function model and State Space model.

- b) Diagonalize the system matrix given below.

[4+6]

$$A = \begin{bmatrix} 0 & 1 & 0 \\ 0 & 0 & 1 \\ -2 & -5 & -4 \end{bmatrix}$$

---ooOoo---

Code No: 134AM

JAWAHARLAL NEHRU TECHNOLOGICAL UNIVERSITY HYDERABAD**B.Tech II Year II Semester Examinations, December - 2018****CONTROL SYSTEMS****(Common to EEE, ECE, EIE)****Time: 3 Hours****Max. Marks: 75****Note:** This question paper contains two parts A and B.

Part A is compulsory which carries 25 marks. Answer all questions in Part A.

Part B consists of 5 Units. Answer any one full question from each unit. Each question carries 10 marks and may have a, b, c as sub questions.

PART- A**(25 Marks)**

- 1.a) Explain how feedback effects overall gain of the system. [2]
- b) State and explain Mason's gain formula. [3]
- c) What is meant by characteristic equation? [2]
- d) What are the standard test signals? [3]
- e) What are the limitations of Routh's stability? [2]
- f) What are frequency domain specifications? [3]
- g) Explain Lag compensation. [2]
- h) What is the difference between polar plot and Nyquist plot? [3]
- i) What are the properties of state transition matrix? [2]
- j) What is meant by state in control system? [3]

PART – B**(50 Marks)**

2. Derive an expression for the transfer function of an armature controlled DC servo motor. [10]

OR

- 3.a) Obtain the transfer function for the following mechanical translational system figure 1.

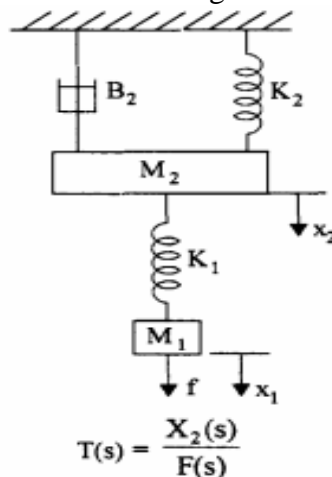
**Figure 1**

- b) Obtain the transfer function for the following mechanical translational system figure 2.

[5+5]

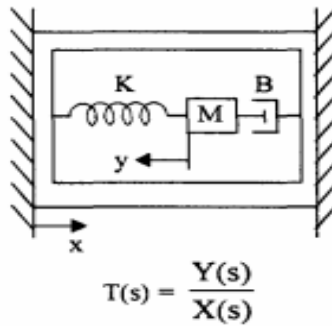

Figure 2

- 4.a) Write the equations for time domain specifications of a standard second order system with unit step input.
- b) Explain the effect of Proportional control action on the performance of a second order system.

[5+5]

OR

5. Consider the system shown in the Figure 3. With switch K open, determine the damping factor and the natural frequency of the system. If a unit ramp input is applied to the system, find the steady state output. Take $K_A = 5$. The damping factor is to be increased to 0.7 by including a derivative output compensation. Find the value of k_t to achieve this. Find the value of undamped natural frequency and the steady state error due to a unit ramp input.

[10]

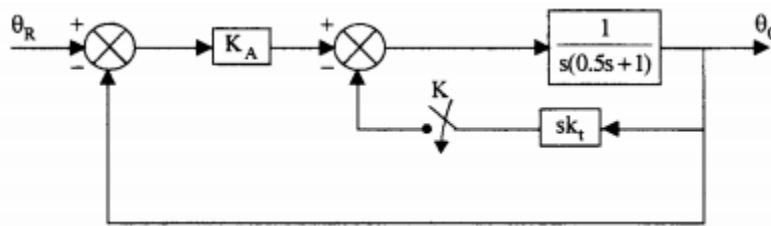

Figure 3

6. A unity feedback system has an open loop function $G(s) = \frac{k}{s(s^2 + 3s + 10)}$ make a rough sketch of root locus plot by determining the following (a) Centroid, number and angle of asymptotes (b) angle of departure of root loci from the poles (c) Breakaway points if any.

[10]

OR

7. Sketch the Bode plot for the following transfer function and determine the system gain K for which the magnitude plot crosses the 0 db line at $\omega = 15$ rad/sec.

[10]

$$G(s) = \frac{K}{s(s+1)(1+0.1s)(1+0.01s)}$$

- 8.a) Draw the complete Nyquist plot for the following open loop transfer function $G(s)H(s) = \frac{2(s+0.25)}{s^2(s+1)(s+0.5)}$. If the system is unstable, how many poles of the closed loop system are in the right half of s-plane?

- b) Draw the electrical circuit diagram that represents the Lead-Lag compensator and explain in detail.

[5+5]

OR

- 9.a) Consider the following polar plot shown in Figure 4. If now a pole at origin and a pole at $s = -\frac{1}{T_2}$ are added, sketch the polar plot.

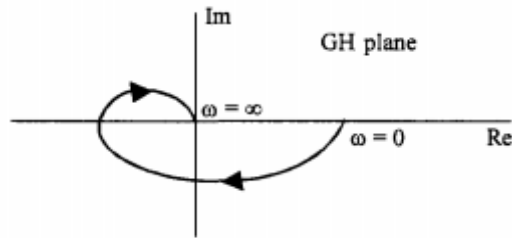

Figure: 4

- b) Design a lag lead compensator for the unity feedback system with, $G(s) = \frac{K}{s(s+1)(s+2)}$ and satisfying the specifications, $K_v = 10 \text{ sec}^{-1}$, $\phi_{pm} = 50^\circ$ and $B.W > 2 \text{ rad/sec}$. [5+5]
- 10.a) Explain various methods of evaluation of state transition matrix.
b) Obtain the transfer function for linear time invariant system and also draw the state model. [5+5]

OR

11. Determine the state and output equations in vector matrix form for the system whose transfer function is given by $G(s) = \frac{s+2}{s(s^2+4s+3)}$. [10]

---ooOoo---

Code No: 134AM

JAWAHARLAL NEHRU TECHNOLOGICAL UNIVERSITY HYDERABAD

B.Tech II Year II Semester Examinations, December - 2019

CONTROL SYSTEMS

(Common to EEE, ECE, EIE, ETM)

Time: 3 Hours

Max. Marks: 75

Note: This question paper contains two parts A and B.

Part A is compulsory which carries 25 marks. Answer all questions in Part A.

Part B consists of 5 Units. Answer any one full question from each unit.

Each question carries 10 marks and may have a, b, c as sub questions.

PART- A

(25 Marks)

- 1.a) What are the different types of control system? [2]
- b) What is the difference between AC servo motor and D.C servo motor? [3]
- c) What is the difference between type and order of a system? [2]
- d) What is the need of PID controller? [3]
- e) What is the necessary condition that the characteristic equation of a feedback system satisfies the BIBO stability? [2]
- f) What are the advantages of frequency domain analysis? [3]
- g) State the Nyquist criterion. [2]
- h) What is the effect on polar plot if a pole is added to the transfer function? [3]
- i) What is state? [2]
- j) What are the advantages of state variable techniques? [3]

PART-B

(50 Marks)

- 2.a) Contrast differences between open loop and closed loop control systems.
- b) Develop the differential equations governing the mechanical system as shown in below figure. Also find the transfer function $\frac{x_1(S)}{F(S)}$. [5+5]

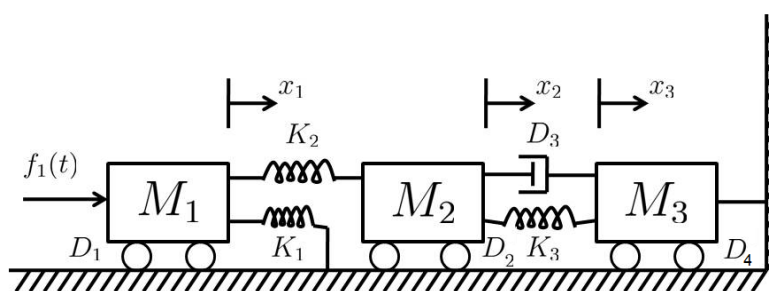

OR

3. Describe the construction and operating principle of synchro transmitter with neat diagrams. [10]
- 4.a) Derive the time domain specifications of second order system with unit step input.
- b) A unity feedback system has a forward path transfer function $G(s) = \frac{8}{s(s+2)}$. Find the value of damping ratio, undamped natural frequency of the system, percentage overshoot, peak time and settling time. [5+5]

- 5.a) Derive the response of second order system with unit step response.
 b) For a negative feedback control system $G(s) = \frac{8}{s(0.4s+1)}$ and $H(s) = \frac{7}{s+2}$. Using generalized error series determine the steady state error of the system when the input applied is $r(t) = 1+2t+5t^2$. [5+5]

- 6.a) Determine the number of roots of a given polynomial with real parts between zero and -1 , $7s^2 + 4s^4 + 10s^3 + 2s^2 + 3s + 6 = 0$
 b) Define and derive the breakaway point on the root locus. [5+5]

OR

7. Sketch the Bode plot and determine the Gain margin and phase margin. For the open transfer function is given, $G(s) = \frac{8}{s(1+0.3s)(1+0.1s)}$. [10]

- 8.a) Describe the procedure for developing the polar plot.
 b) A unity feedback control system has an open loop transfer function given by $G(s)H(s) = \frac{10}{s(s+3)(s+6)}$. Draw Nyquist diagram and determine stability. [5+5]

OR

9. Consider the open loop transfer function with unit feedback system,

$$G(s) = \frac{k}{s(s+3)(0.4s+1)}$$

Design the lead-lag compensator so that:

- a) Velocity error constant K_v is 5 sec^{-1}
 b) Phase margin not greater than 30°
 c) Gain margin not greater than 10 db. [10]

- 10.a) Obtain the state space representation of an n^{th} order differential equation.

- b) A second order linear system is described by

$$\dot{x}_1 = -2x_1 + 4x_2 + u$$

$$\dot{x}_2 = -x_1 - 2x_2 + u$$

$$\text{and } y = x_1 + x_2$$

Find the transfer function and also calculate the zero input response of $x_{1(0)} = 1$ and $x_{2(0)} = -1$. [5+5]

OR

11. The state variable formulation of a system is given by

$$\begin{bmatrix} \dot{x} \end{bmatrix} = \begin{bmatrix} -3 & 2 \\ -1 & 0 \end{bmatrix} [x] + \begin{bmatrix} 0 \\ 1 \end{bmatrix} u \text{ and } y = \begin{bmatrix} 1 & 0 \end{bmatrix} [x].$$

Find the following:

- a) Transfer function of the system
 b) State transaction matrix and
 c) State equation for a unit step input under zero initial condition. [10]

---ooOoo---

Code No: 55012

JAWAHARLAL NEHRU TECHNOLOGICAL UNIVERSITY HYDERABAD

B. Tech III Year I Semester Examinations, December - 2019

CONTROL SYSTEMS
(Common to EEE, ECE, ETM)

Time: 3 hours

Max. Marks: 75

Answer any five questions
All questions carry equal marks

- 1.a) What do you mean by the sensitivity of the control system and discuss the effect of feedback on sensitivity.
- b) Determine the transfer function for the mechanical system shown in below figure. [8+7]

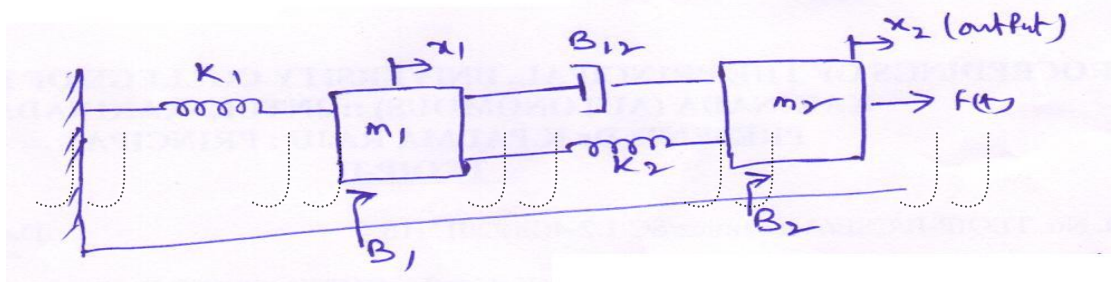

- 2.a) Derive the transfer function for AC servo motor? Explain its torque- speed characteristics.
- b) Describe the Synchro pair as error detector with circuit diagram. [8+7]
- 3.a) Derive the time domain specifications of second order system with unit step input.
- b) A unity feedback system is characterized by an open loop transfer function.

$$G(s) = \frac{K}{s(s+6)}$$

Determine the gain K so that the system will have a damping factor of 0.3. For this value of K determine the natural frequency of the system. It is subjected to a unity step input. Obtain the closed loop response of the system in time domain. [7+8]

- 4.a) Explain the construction rules for root locus technique.
- b) Determine the stability of the closed loop system whose open loop transfer

$$\text{is } \frac{10(3s+1)}{s(s+1)(1+6s)(1+0.1s)}$$

Using Routh-Hurwitz criterion.

[7+8]

- 5.a) Define the gain margin and phase margin. Explain the significance of these terms to find the closed loop system stability.
- b) Determine the resonant frequency ω_r , resonant peak M_p and bandwidth for the system whose transfer function is [7+8]

$$G(j\omega) = \frac{5}{5 + j2\omega + (j\omega)^2}$$

6.a) Explain the procedure for constructing the polar plots.

b) Given the open loop transfer function $G(s) = \frac{1}{(1+s)(2+s)}$. Sketch the Nyquist diagram and investigate the stability of the closed loop system. [7+8]

7. Consider a unity feedback system with open loop transfer function.

$G(s) = \frac{K}{s(1+s)(2+s)}$, design a suitable compensator so that the compensated system

has

a) $K_v = 10 \text{ sec}^{-1}$

b) Phase margin = 50°

c) Gain margin $\leq 10 \text{ db}$. [15]

8.a) What are the merits of state variable techniques?

b) State and explain the controllability and observability of a system. [7+8]

---ooOoo---